

Battlefield Information Services (BIS)

Contents

	Page
Preface	iii
Chapter 1	Operational Concept
	1-1
	1-1. Background
	1-1
	1-2. BIS Responsibilities
	1-2
	1-3. BIS Management
	1-4
Chapter 2	Information Services Support Office
	2-1
	2-1. Mission
	2-1
	2-2. Functions
	2-1
	2-3. Organization
	2-1
	2-4. Section Personnel and Responsibilities
	2-2
Chapter 3	Printing and Publications
	3-1
	3-1. Printing Responsibilities
	3-1
	3-2. Publications Responsibilities
	3-4
	3-3. Forms Management Responsibilities
	3-8
	3-4. Reproduction Responsibilities
	3-9

**Unless this publication states otherwise,
masculine nouns and pronouns do not refer
exclusively to men.**

Distribution Restriction: Approved for public release; distribution is unlimited.

	Page
Chapter 4	Records Management 4-1
	4-1. Overview 4-1
	4-2. Correspondence Responsibilities 4-1
	4-3. Files Management Responsibilities 4-3
	4-4. FOIA/PA Responsibilities 4-4
	4-5. Classified Document Control Responsibilities 4-8
	4-6. Distribution/Official Mail Responsibilities 4-11
Glossary	Glossary-1
References	References-1
Index	Index-1

Preface

Purpose and Scope

This manual establishes procedures and techniques for the Information Mission Area (IMA) disciplines of printing, publications, and records management. These disciplines include the following battlefield information services (BIS):

- Printing.
- Publications.
- Forms management.
- Reproduction.
- Classified document control.
- Distribution/official mail.
- Correspondence.
- Files management.
- Freedom of Information Act (FOIA)/Privacy Act (PA).

This manual provides doctrinal guidance for applying BIS in the tactical environment.

FM 24-1, *Signal Support in the AirLand Battle*, provides the doctrinal base for the IMA disciplines: communications, automation, visual information, printing, publications, and records management. The IMA disciplines of printing, publications, and records management do not stand alone, but integrate into the other IMA disciplines. Commanders should use this manual with FM 24-1 to ensure this integration takes place.

The intent of this publication is to provide guidance to Information Services Support Offices (ISSOs), commanders, and staff officers across the operational continuum.

User Information

The proponent of this publication is HQ TRADOC. Send comments and recommendations on DA Form 2028 directly to Commander, United States Army Signal Center and Fort Gordon, ATTN: ATZH-DTL, Fort Gordon, Georgia 30905-5075. Key comments and recommendations to pages and lines of text to which they apply. If DA Form 2028 is not available, a letter is acceptable. Provide reasons for your comments to ensure complete understanding and proper evaluation.

Chapter 1

Operational Concept

1-1. Background

a. Battlefield Information Services (BIS) are information services provided on the battlefield. They combine the Information Mission Area (IMA) disciplines of printing, publications, and records management. BIS include functions and resources used to organize, distribute, retrieve, dispose, and manage all records, regardless of media.

b. Under the IMA, signal organizations provide information services in garrison as well as when a unit deploys. In garrison, the Director of Information Management (DOIM) organization supplements these services. When a maneuver unit deploys, the organic signal element provides information services in the combat environment. These services are tailored to the commanders' battlefield needs using the unit's organic equipment.

c. BIS are essential information services needed to support the maneuver commander in the field and do not duplicate the services in garrison. In garrison, information services are more extensive than those for the deployed unit. In garrison, the DOIM supplements the installation's post and units with information services and resources which are external to the maneuver unit. For example, when a corps or division is in garrison, the DOIM provides support for information services; printing; automated systems; and post, camp, and station telephone access. When the unit deploys, its organic signal element ensures essential BIS are provided in a tactical environment.

d. The signal element provides essential information services or BIS. The BIS are defined below. See References for appropriate regulatory publications.

(1) **Printing.** Printing is the processes of composition, plate making, press work, and binding to include micropublishing for producing publications. Printing is putting an image on paper in volumes over 5,000 units of a single original and no more than a total of 25,000 units of a multipage document.

(2) **Publications.** Publications are items on which information is printed or reproduced, mechanically or electronically, for distribution. They include directives, pamphlets, posters, forms, manuals, brochures, magazines, and newspapers produced in any printed media for the Army.

(3) **Forms management.** Forms are officially prescribed documents with prepared spaces for inserting information.

FM 11-75

(4) **Reproduction.** Reproduction is recreating an original document by mechanical means. These means include printing, duplicating, and copying which are defined in AR 25-30. In the field, this is done by automatic copying-processing, copier-duplicating, or printing machines using electrostatic, thermal, or other copying processes.

(5) **Classified document control.** Classified document control are procedures developed to ensure classified material is accounted for and protected. See AR 380-5 for further guidance.

(6) **Distribution/official mail.** Distribution is a system for providing receipt, collation, additional reproduction, and the proper routing of messages and printed material in a specific organization or between organizations. Official mail is part of the distribution system. It contains official information and is normally addressed to the commander of a military unit. Delivering mail is a US postal responsibility. However, when official mail is turned over to the Army, the Signal Corps' Information Services Support Office (ISSO) assumes distribution responsibility. See AR 25-51 for further guidance.

(7) **Correspondence.** Correspondence refers to communications media which may be produced, reproduced, or transmitted manually or electronically. It may also be magnetic media or other special purpose correspondence or forms used in official Army business. Correspondence includes all forms and formats contained in AR 25-50.

(8) **Files/records management.** Files consist of any materials created, saved, or stored. These include books, papers, maps, photographs, machine readable materials, or other documentary materials regardless of content, or their physical form. See AR 25-400-2 for further guidance.

(9) **Freedom of Information Act (FOIA).** The FOIA program implements DOD policy. This policy requires activities be conducted in an open manner consistent with the need for security and adherence to other requirements of law and regulation. The program's objective is to ensure that only information which is exempt from disclosure by the FOIA is withheld from the public. See AR 25-55 for further guidance.

(10) **Privacy Act (PA).** The PA program protects an individual's privacy from unwarranted invasion. This is done by ensuring the recorded information about the individual is necessary, timely, accurate, complete, and confidential. See AR 340-21 for further guidance.

1-2. BIS Responsibilities

a. Information management is a command responsibility at all levels. The signal element is the executive agent for providing BIS in the field.

b. The signal commander/staff is responsible for managing BIS for the maneuver commander. To aid in this effort, division-size or larger units have a staff element. This staff element is the ISSO. In units without an ISSO, the S1 is responsible for performing and managing BIS. These units are the maneuver brigade and the battalion. The requirement for BIS at the maneuver brigade is minimal because of the maneuver unit's mission.

c. The signal element provides a framework or procedural guidance for functional staffs to operate, obtain, or perform information services. The functional user/staff receives, passes, and obtains information within the BIS framework.

d. The signal element establishes the framework and format for services. However, the functional proponent/user is responsible for the content. For example, the signal element is responsible for controlling and providing guidance on forms management or developing a uniform records management system (files) IAW AR 25-400-2. The functional user is responsible for the design and content of the form or information contained within the file. The ISSO establishes classified document control procedures; however, the user is responsible for generating and storing classified material.

e. The operating element that provides BIS, under the control of the signal commander, is the ISSO.

f. Division, corps, and theater levels have an ISSO. The ISSO coordinates and supports BIS requiring centralized management internal to the headquarters. It also guides and regulates services that are not centrally managed. The ISSO falls under the assistant corps signal officer's (ACSO) control at corps and the assistant division signal officer's (ADSO) control at division.

g. The theater has an ISSO and an Information Services Support Branch (ISSB). The ISSO is an element of the office of the Chief of Staff. The ISSB is assigned to the Deputy Chief of Staff for Information Management (DCSIM). The ISSB oversees theater BIS which include operations of reproduction detachments, and it coordinates BIS requirements with the sustaining base.

h. At battalion and brigade, the S1 performs ISSO functions. The functional staff officers (S1, S2, S3, S4) execute services in their respective staff sections. Users are responsible for obtaining and following their unit's BIS directives.

i. The primary functions of the ISSO are--

(1) Providing centralized management and executing distribution, reproduction, publications and forms account management, and FOIA/PA at division, corps, and theater.

(2) Advising and assisting the commander with BIS.

FM 11-75

(3) Providing staff supervision for all BIS to units and tenant units in the field.

j. Figure 1-1 shows the BIS organization from theater through battalion.

1-3. BIS Management

BIS is managed through direct control of the activity or through promulgation of policies. Management by policy occurs when the signal element sets the policy and the user follows the policy.

a. **Direct action.** Under the control of the signal element, a specified point of contact (POC) receives and routes all requests concerning a service. Distribution, reproduction, and FOIA/PA require direct control or action.

(1) **Distribution.** The ISSO/S1 establishes a distribution process and is responsible for internal distribution. Internal distribution is the distribution between functional staff elements of the same headquarters including official mail. External distribution is the movement of official mail (including publications) and distribution between command posts (CPs). Official mail requires postage once it enters the Army postal office. At division and above, the ISSO provides the distribution center. At brigade and below, the S1 provides the distribution center. The recipient is responsible for collecting the distribution from the distribution center.

(2) **Reproduction requirements.** Reproduction requirements are centrally managed through the ISSO. The ISSO receives user printing requests and routes them to the theater printing detachments or the proper sustaining base supporting activity. The user is responsible for his own organic reproduction equipment; for example, topographic, psychological, and intelligence operations and public affairs reproduction applications.

(3) **FOIA/PA.** Requests for information and PA administration require centralized execution. The ISSO/S1 is the central POC for all FOIA/PA requests. His responsibility is to determine the appropriate approving authority for FOIA/PA requests.

b. **Management by policy.** The signal element sets local policies by supplementing standing regulations. The functional staff and users are responsible for their own BIS requirements. Users must comply with appropriate ARs and local policies promulgated by the ISSO.

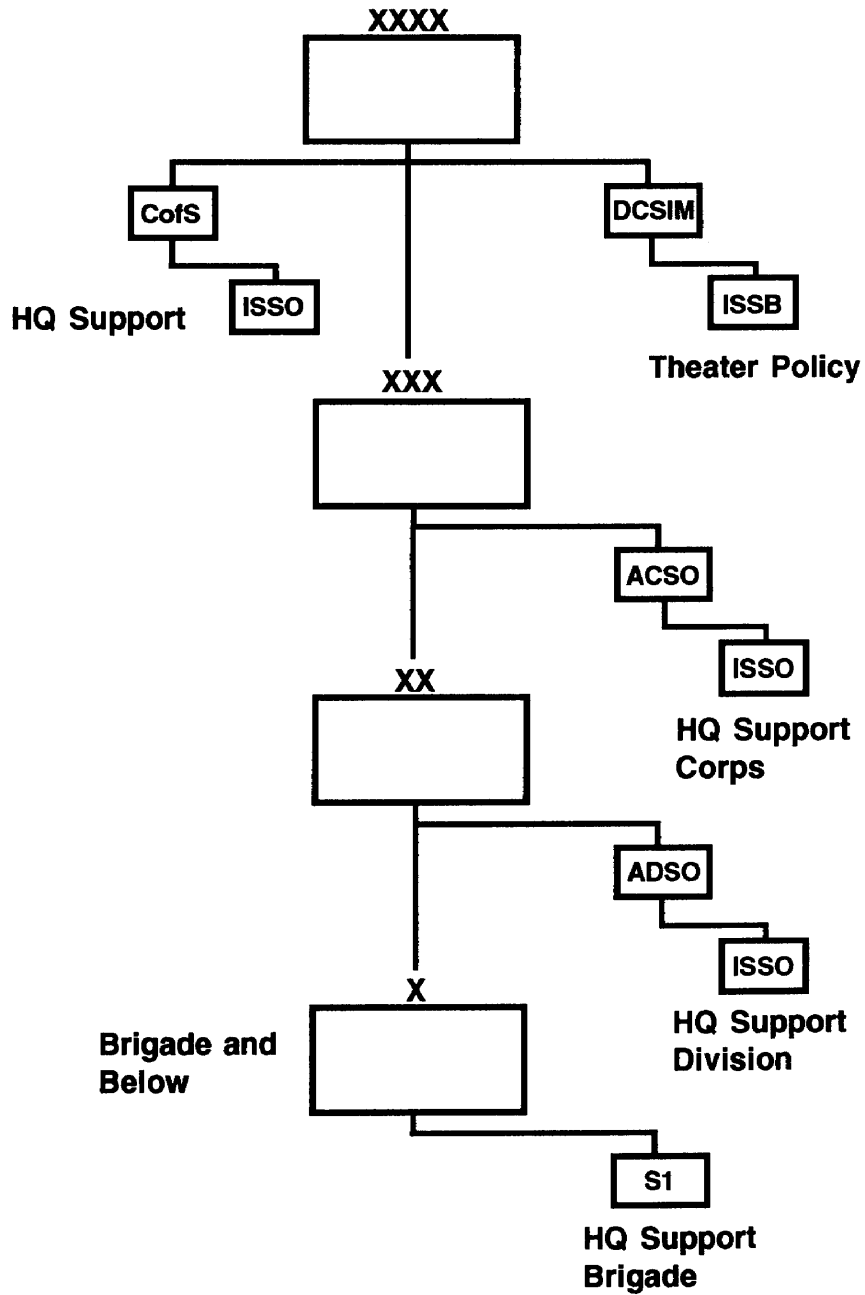

Figure 1-1. BIS organization.

Chapter 2

Information Services Support Office

2-1. Mission

The ISSO's primary mission is to provide BIS and policies to the commander. It also coordinates distribution/official mail, reproduction requests, and FOIA/PA for the organization. Additionally, the ISSO recommends policy, directs, and supervises staff and users in the areas of correspondence, classified document control, and publications, forms, and files management.

2-2. Functions

- a. The ISSO provides--
 - Distribution of official mail, reproduction, FOIA/PA support to the division, corps, and theater staff.
 - Staff advice on information services functions.
 - Technical assistance to information services support facilities and to subordinate units within the command.
- b. The ISSO serves as a staff and technical supervisory agency. This office establishes and monitors commandwide programs for BIS and provides BIS training.

2-3. Organization

- a. The ISSOs at division, corps, and theater provide the same basic functions. The difference is the level of support the ISSO provides at each echelon.
- b. The theater has an ISSO and an ISSB.
 - (1) The ISSO is responsible to the Chief of Staff of the theater signal command and is responsible for the internal information needs for the theater Army. The theater ISSO coordinates reproduction requests and controls the theater reproduction detachments.
 - (2) The ISSB works at the direction of the signal support division and is assigned to the DCSIM. The ISSB issues policies and procedures for corps and below. It also

FM 11-75

manages, prepares, coordinates, and develops the theater Army capability analysis, BIS management, and combat camera operations.

c. The ISSO has three sections. These are the headquarters and operations section, the publications and reproduction section, and the records management and distribution section. Figure 2-1 illustrates an example of the ISSO's organization.

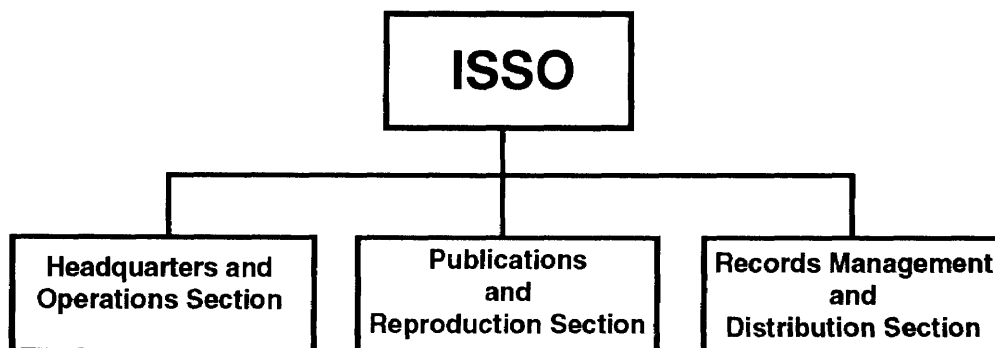

Figure 2-1. An example of a theater, corps, or division ISSO organization.

2-4. Section Personnel and Responsibilities

a. **Headquarters and Operations Section.** This section provides staff supervision over the information services support program within the division, corps, and theater. It--

(1) Establishes policies and prepares command policies on BIS for each respective level of command.

(2) Establishes a distribution/official mail pickup and delivery schedule, a routing guide, and information on procuring tactical reproduction services. The user is responsible for procuring equipment and contracting services.

(3) Prepares guidelines on preparing, coordinating, routing, and dispatching correspondence through the ISSO distribution center.

(4) Develops policies on centralized reproduction services for the classified correspondence repository. This repository is the responsibility of the ISSO until distribution is made to the user.

(5) Performs staff supervision of the FOIA/PA. Recommending policies, procedures, and conventions, and serves as the central POC within the command for FOIA/PA requests, It refers related requests to the proper staff element or personnel services support activity.

(6) Provides technical assistance to subordinate units of the command by establishing and monitoring commandwide programs for BIS support.

(7) Keeps the staff and command group informed of the information services support situation via the signal officer.

(8) Maintains a current reference library of ARs, published command guidance, and other regulatory guidance on all BIS. These references are needed to perform staff supervision functions, to establish policies, to support the command group, and to prepare the ISSO's standing operating procedure (SOP).

b. Publications and Reproduction Section. This section--

(1) Performs staff supervision of reproduction, publications, and forms management. It recommends policies, procedures, standards, and conventions. When warranted, staff elements at theater and below will establish their own publications and forms account (see DA Pamphlet 25-33). This is usually due to location and special requirements.

(2) Establishes copying, duplicating, and printing control IAW with AR 25-30.

(3) Provides supplemental high-volume reproduction/copying services for command, staff, signal headquarters, and subordinate units as necessary. Provides reproduction support to meet the requirements of the ISSO.

(4) Serves as the central POC within the command for printing support requests. It verifies the format of user printing requests and forwards them through channels to the proper signal theater reproduction detachment or sustaining base printing support activity (DOIM).

(5) Reviews requests and assists users with technical specifications for procuring user-owned reproduction equipment.

(6) Provides information on sources through which the devices may be procured; however, users are responsible for determining their own reproduction requirements. If the user identifies high-volume reproduction requirements, this section validates and forwards the requirements to the appropriate organization for action.

(7) Operates and manages the division, corps, and theater headquarters publications and forms control programs.

FM 11-75

(8) Prepares an index of headquarters publications and forms and establishes and maintains distribution plans for headquarters publications.

(9) Reviews and submits requisitions for reproduction and publications support for the headquarters staff elements.

(10) Establishes both headquarters and command initial distribution of publications and forms to the unit staff, headquarters elements attached to the headquarters, and subordinate units.

(11) Maintains required DA publications (excluding technical publications). It also keeps other official forms for the unit staff. These functions are performed by the functional staff/user in the organizational elements within division, corps, and theater boundaries without organic ISSOs/S1s.

(12) Maintains an internal stock of DA regulations, other publications, and forms IAW operational needs. It keeps the amount and type needed to support associated information services support activities. In coordination with the ISSO, functional staff elements requisition, issue, and maintain publications and forms. They also track receipt of requisitions and dispose of expired publications and forms.

(13) Provides specific publications for the headquarters staff. In addition, it maintains an internal ISSO library of information services publications. This section maintains publications needed to provide staff supervisory support to associated ISSOs and functional information services activities.

(14) Approves user requests for new forms. Functional users must follow forms usage and generation policies, including use management and requesting resupply.

c. **Records Management and Distribution Section.** This section--

(1) Performs staff supervision of files management, classified document control, and distribution/official mail. It recommends policies, procedures, standards, conventions, and inspections as applicable.

(2) Establishes and monitors the records management program. This program includes correspondence, maintenance, management, and disposition of files. It also monitors adherence to the records management program and suggests corrective measures as needed. It maintains liaison with records management staff elements throughout the command.

(3) Advises users/functional staffs on files management as it applies to FOIA/PA.

(4) Approves files listings and electronic filing. Analyzes and evaluates proposals, studies, and equipment requests for micrographic, magnetic, optical, and electronic records systems.

(5) Recommends classified document control policies, procedures, standards, and inspections in all phases and areas of IMA. This includes correspondence, printing, reproduction, distribution/official mail, and files management.

(6) Determines routes and schedules for a classified courier system (in coordination with the G2). The G3 tasks units for personnel and equipment to man the courier system. This section stores classified documents until distribution occurs.

(7) Coordinates with the G2 on evacuation plans, headquarters' classified documents, and material held by the ISSO awaiting distribution.

(8) Operates the headquarters central distribution center and serves as the primary POC within the command for internal headquarters distribution. Headquarters staff elements are responsible for collecting their own distribution/official from the distribution center.

(9) Advises subordinate commands on postal matters.

(10) Provides external distribution services. This section recommends policies, procedures, and conventions. It also prepares guidelines on preparing, coordinating, routing, and dispatching correspondence through the ISSO distribution center. This section receives, controls, and distributes all official publications and correspondence (except electrically transmitted messages). It coordinates requirements for messengers and classified document couriers as required.

(a) The signal officer determines messenger routes and schedules and coordinates messenger resources with the G3. Maximum use will be made of existing delivery systems.

(b) Messenger service is an unresourced signal mission (see FM 24-1). Until the mission is resourced, the signal officer ensures that messenger service is provided with augmentation by supported units. Personnel assigned to the ISSO are not resourced as messengers. However, the signal officer may use the ISSO to control messenger service.

(11) Coordinates with the appropriate telecommunications activities on receiving, controlling, and delivering electrically transmitted messages addressed to the ISSO.

Chapter 3

Printing and Publications

3-1. Printing Responsibilities

a. Overview.

(1) There is no organic printing capability at corps and below. If the unit has a large printing requirement, the ISSO validates, prioritizes, and forwards the request through channels to the appropriate organization. All ISSO/S1 officers are responsible for verifying the correct format of material and requests IAW AR 25-30. The ISSO has no involvement in topographic, psychological, or intelligence operations.

(2) The ISSO validates the printing requirements at corps and division. Organic reproduction devices include personal and unit-level computers, tactical deployable duplicators (TDDs), tactical document copiers (TDCs), and subscriber terminals. Reproduction detachments provide printing services to organic and nonorganic units in their area of operation.

b. ISSO.

(1) The ISSO serves as the central POC within the command for high- and medium-volume printing support requests. It verifies the format and forwards the requests through channels to the appropriate signal theater reproduction detachment or sustaining base printing facility.

(2) Theater reproduction detachments are assigned to the signal battalion which is organic to the theater Army signal brigade assigned to the Theater Signal Command (Army) TSC(A). This unit provides volume printing services on a 24-hour basis. Printing services include collating, binding, and packaging. TSC(A) reproduction detachments provide volume printing for all theater units not supported by organic volume printing capabilities.

c. **S1.** At brigade and below, the S1 approves and validates all printing requests and forwards them to the ISSO.

d. Functional Staff/User.

(1) Staff and users at all levels will forward reproduction requirements beyond their capabilities to the ISSO for disposition. At division and below, the tactical document copier is authorized for small reproduction requirements. The next higher command through the ISSO provides any printing needs beyond the unit's capability.

FM 11-75

(2) The fictional staff officer is responsible for installing, operating, and maintaining organic reproduction equipment to support his own low-volume requirements. These requirements include organic reproduction equipment and peripheral printing devices connected to organic computers and battlefield automated systems (BAS).

(3) The signal officer is not responsible for organic reproduction equipment. This includes topographic, psychological, or intelligence operations and public affairs reproduction applications.

e. **Printing.** Table 3-1 lists the printing responsibilities from battalion through theater. Figure 3-1 illustrates the printing process.

Table 3-1. Printing responsibilities.

PRINTING				
ISSO refers to Signal Corps responsibilities, user refers to user responsibilities, staff refers to functional staff responsibilities, and S1 refers to S1 responsibilities. S1 provides all ISSO services at battalion and brigade.				
RESPONSIBILITIES	BN	BDE	DIV/CORPS	THEATER
POC for any request to be forwarded	S1	S1	ISSO	ISSO
There is no printing capability at corps and below. If the need arises, the ISSO/S1 forwards the request through signal channels to the appropriate organization. The ISSO/S1 is responsible for verifying correct formatting of material and requests. The ISSO has no involvement in topographic, psychological, intelligence operations at corps.				

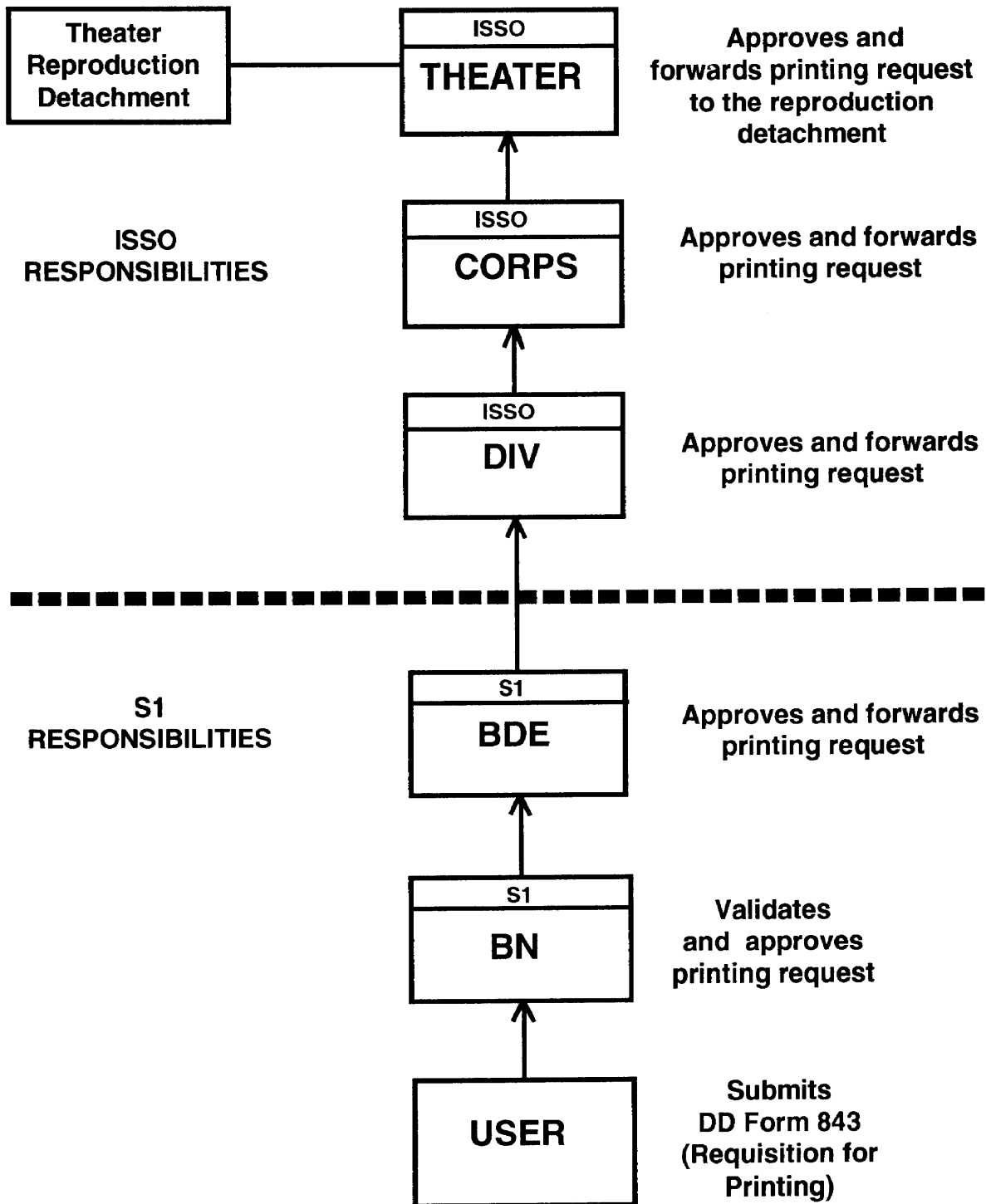

Figure 3-1. Printing process.

3-2. Publications Responsibilities

a. **Overview.** The ISSO is responsible for staff supervision of publications at division, corps, and theater. It recommends policies, procedures, and conventions for publications IAW AR 25-30. At brigade and below, the S1 is responsible for publications. When units enter the theater, the theater ISSO or the highest echelon ISSO assigns them a battlefield account number (BAN). The United States Army Printing and Publications Command (USAPPC) has set aside a specific block of BANs available for deployed units only. Units authorized the BAN will receive priority for all publications/forms requirements. The BAN allows units to requisition publications expeditiously in a tactical environment. Before deployment, units should ensure they have enough publications to accomplish their wartime mission for 90-120 days.

b. **ISSO.** The ISSO--

- Maintains the unit's publications account.
- Controls and prepares an index of headquarters publications (except combat operations orders).
 - Reviews and approves publications requirements and ensures that required publications are correctly reflected on DA 12-series forms.
 - Prepares and submits requisitions for administrative, training, doctrinal, and technical publications for headquarters staff and attached elements.
 - Establishes both headquarters and command initial distribution of publications and forms to the unit staff, headquarters elements attached to the headquarters, and subordinate units.
 - Establishes and maintains a stock of DA publications and blank forms for the headquarters staff and attached elements.
 - Maintains a library of administrative publications for the headquarters staff. The publications section maintains technical publications IAW its operational needs.
 - Controls the storage and use of classified, accountable, and sensitive publications and forms IAW AR 25-30.
 - Reviews the annual initial distribution requirements printout received from the USAPPC.
 - Ensures that publications account personnel are properly trained and are familiar with this manual, AR 25-30, and DA Pamphlet 25-33.

c. **S1.**

(1) At brigade and battalion, the S1 is the unit publications account manager and is responsible for consolidating, ordering, and distributing subordinate unit publications requests.

(2) For units at battalion and below, the S1 ensures that publications and forms are properly forwarded to the subordinate units that requested them.

d. **Functional Staff/User.** Staff/Users--

- Identify publications and forms requirements.
- Identify correct quantity of publications.
- Manage their own publications accounts IAW AR 25-30.
- Notify the ISSO when moving throughout the battlefield so APOs can be adjusted.

e. **Publications.** Table 3-2 lists the publications responsibilities from battalion through theater. Figure 3-2A illustrates publications and forms distribution using the BAN. Figure 3-2B illustrates the interim procedure until the BAN is established.

Table 3-2. Publications responsibilities.

PUBLICATIONS				
<p>SigO and ISSO refer to Signal Corps responsibilities, user refers to user responsibilities, staff refers to functional staff responsibilities, and S1 refers to S1 responsibilities. S1 provides all ISSO services at battalion and brigade.</p>				
RESPONSIBILITIES	BN	BDE	DIV/CORPS	THEATER
Staff supervision of publications recommending policies, procedures, and conventions	SigO	SigO	ISSO	ISSO
Publications account management consolidating, ordering, and distributing subordinate unit requests through the pinpoint distribution system. This function occurs only at the echelon owning the pinpoint account. (see note)	S1	S1	ISSO	ISSO
Identify publications requirement	User	User	User	User
Publications library <ul style="list-style-type: none"> • not a mandatory requirement • when applicable, geared towards user's function (for example, S2 and maintenance) 	User	User	User	User
<p>NOTE: When the user has a separate pinpoint account, the account will be the user's responsibility.</p>				

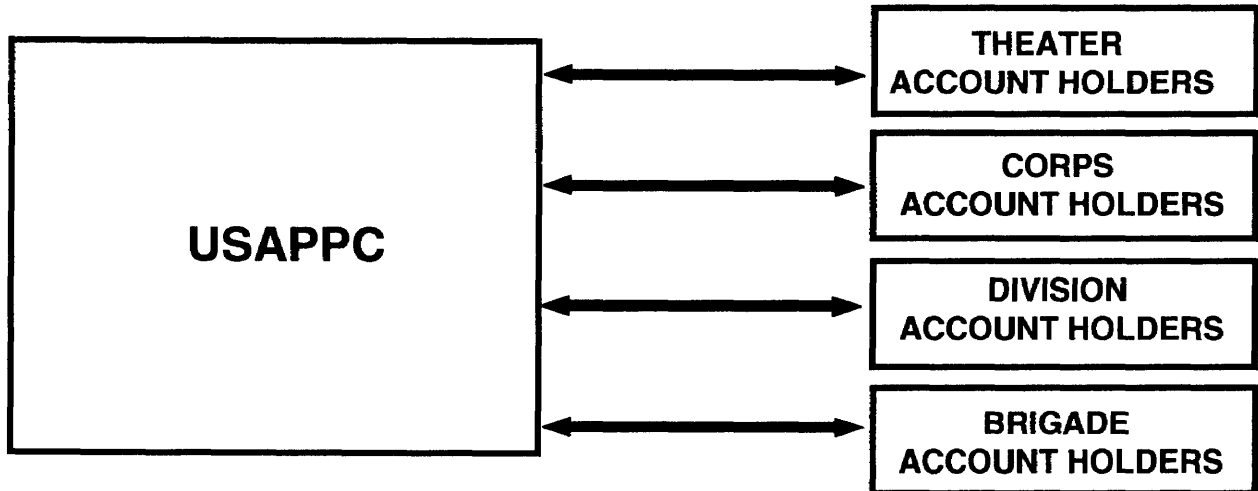

Figure 3-2A. Publications and forms distribution via mail using the BAN.

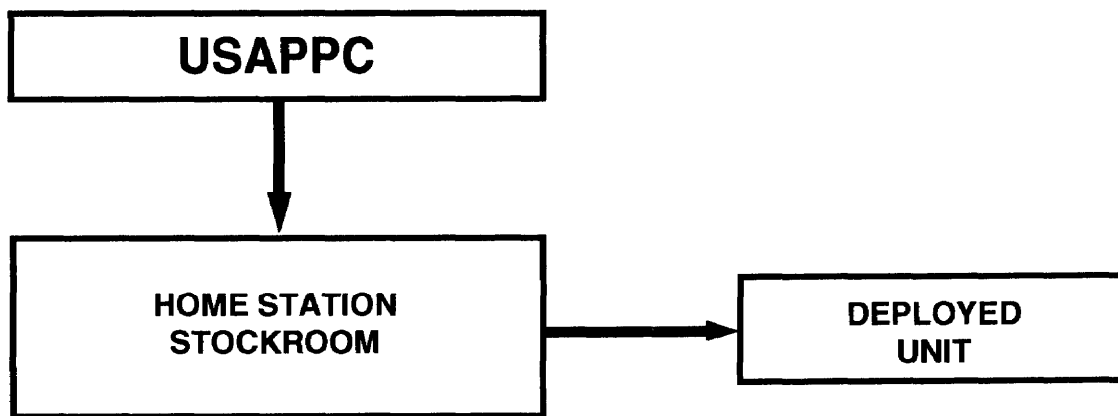

Figure 3-2B. Publications and forms distribution via mail before the BAN is established.

3-3. Forms Management Responsibilities

a. **Overview.** The ISSO is responsible for staff supervision of forms management for the headquarters IAW AR 25-30. At brigade and below, the S1 is responsible for forms management. When units enter the theater, the theater ISSO or the highest echelon ISSO assigns them a BAN. The BAN allows units to requisition and distribute forms in a tactical environment. Before deployment, units should ensure they have enough forms to accomplish their wartime mission for 90-120 days.

b. **ISSO.** The ISSO--

- Recommends and forwards requests for new forms.
- Resupplies forms for the headquarters staff.

c. **S1.** The S1--

• Compiles, orders, and distributes forms. (This function occurs only at elements owning the forms account.)

- Approves forms requests.

d. **Functional Staff/User.** Staff/Users--

- Request resupply of forms through the USAPPC or the ISSO.
- Adhere to forms usage policies. (This includes use management and requesting resupply.)

e. **Forms.** Table 3-3 lists the forms management responsibilities from battalion through theater.

Table 3-3. Forms management responsibilities.

FORMS MANAGEMENT				
SigO and ISSO refer to Signal Corps responsibilities, user refers to user responsibilities, staff refers to functional staff responsibilities, and S1 refers to S1 responsibilities. S1 provides all ISSO services at battalion and brigade.				
RESPONSIBILITIES	BN	BDE	DIV/CORPS	THEATER
Staff supervision of forms management <ul style="list-style-type: none"> recommending policies, procedures, and conventions compiling, ordering, and distributing forms (This function occurs only at the elements owning the pinpoint account.) 	SigO S1	SigO S1	ISSO ISSO	ISSO ISSO
Request for new forms <ul style="list-style-type: none"> recommending approving 	User Staff/S1	User Staff/S1	User ISSO	User ISSO
Adhere to forms usage policy <ul style="list-style-type: none"> includes use management requesting resupply 	Staff/User User	Staff/User User	Staff/User User	Staff/User User

3-4. Reproduction Responsibilities

a. ISSO.

(1) The ISSO has staff supervision of reproduction services. It recommends policies, procedures, and conventions IAW AR 25-30. Reproduction services include duplicating, collating, binding, and packaging. To provide reproduction services, the ISSO is authorized high-volume reproduction equipment. If reproduction requests exceed the volume limits, the requests are forwarded to the reproduction detachment.

(2) The ISSO--

- Manages printing, reproduction, and self-service copying operations for the headquarters staff.

- Approves, validates, and provides reproduction support to meet operational requirements.

FM 11-75

- Provides limited emergency and special purpose reproduction for the headquarters staff and subordinate units when necessary.

- Ensures that proponents request the most economical materials, construction, processes, and number of copies that will achieve the intended purpose of the request.

(3) The ISSO has technical review responsibility for self-service copiers. Self-service copying is automatic and end-user operated. Self-service copy processing produces copies by electrostatic, thermal, or other processes. Self-service copiers should not be consistently used to reproduce more than 25 copies per original.

(4) Self-service copiers will only be moved from one activity to another with notification of the ISSO.

(5) The TDD is for medium- to high-volume duplicating in a tactical environment. Its use in garrison is prohibited. The DOIM through the General Printing Service (GPS) provides duplicating requirements while in garrison. The TSC(A), corps signal brigades, headquarters and headquarters companies, and division signal battalions have authorization for TDDs with speeds of more than 70 copies per minute (CPM). In these TOE/MTOE organizations, the ISSO will operate and maintain the TDD. AR 71-13 and CTA 50-909 (Table 75) authorize acquisitions for TDDs with speeds of up to 130 CPM. The ISSO will forward printing requirements that exceed the definition of duplicating to the first available printing organization.

b. S1/Functional Staff. The functional staff is responsible for--

- Validating, approving, assisting, and advising user requirements for copying.
- Assisting users in procuring organic reproduction/copying equipment.
- Reviewing user requests and providing information and advice on the different classes and technical specifications of reproduction devices IAW AR 25-30.
- Providing information on sources through which the reproduction devices may be procured.

c. User.

(1) Users are responsible for determining their own reproduction requirements. Once the user identifies his reproduction requirements, the functional staff validates the requirements.

(2) Users are responsible for copier operations and maintenance.

(3) A self-service copier may no longer be required or may become unserviceable. In these cases, the user coordinates with the ISSO/S1 to determine proper disposition and to return the copier to the vendor.

(4) Users will normally obtain self-service copier maintenance support while in garrison through the DOIM. Such equipment, whether owned or leased, will become station property. An exception is the acquisition and use of TDCs for MTOE units, activities, or major elements. (See CTA 50-909, Chapter 14, Appendix C, for acquisition authority for these copiers.)

d. **Reproduction.** Table 3-4 lists the reproduction responsibilities from battalion through theater. Figure 3-3 illustrates the reproduction process,

Table 3-4. Reproduction responsibilities.

REPRODUCTION				
<p>SigO and ISSO refer to Signal Corps responsibilities, user refers to user responsibilities, staff refers to functional staff responsibilities, and S1 refers to S1 responsibilities. S1 provides all ISSO services at battalion and brigade.</p>				
RESPONSIBILITIES	BN	BDE	DIV/CORPS	THEATER
Staff supervision of reproduction recommending policies, procedures, and conventions	SigO	SigO	ISSO	ISSO
Tactical deployable duplicator (TDD) operations	*	*	ISSO	ISSO
Copier management				
• determining need for requirement	User	User	User	User
• validating requirement	S1/Staff	S1/Staff	ISSO	ISSO
• assisting/advising in satisfying the requirement	S1/Staff	S1/Staff	ISSO	ISSO
Copier operation and user maintenance	User	User	User	User
* TDDs are not authorized below division.				

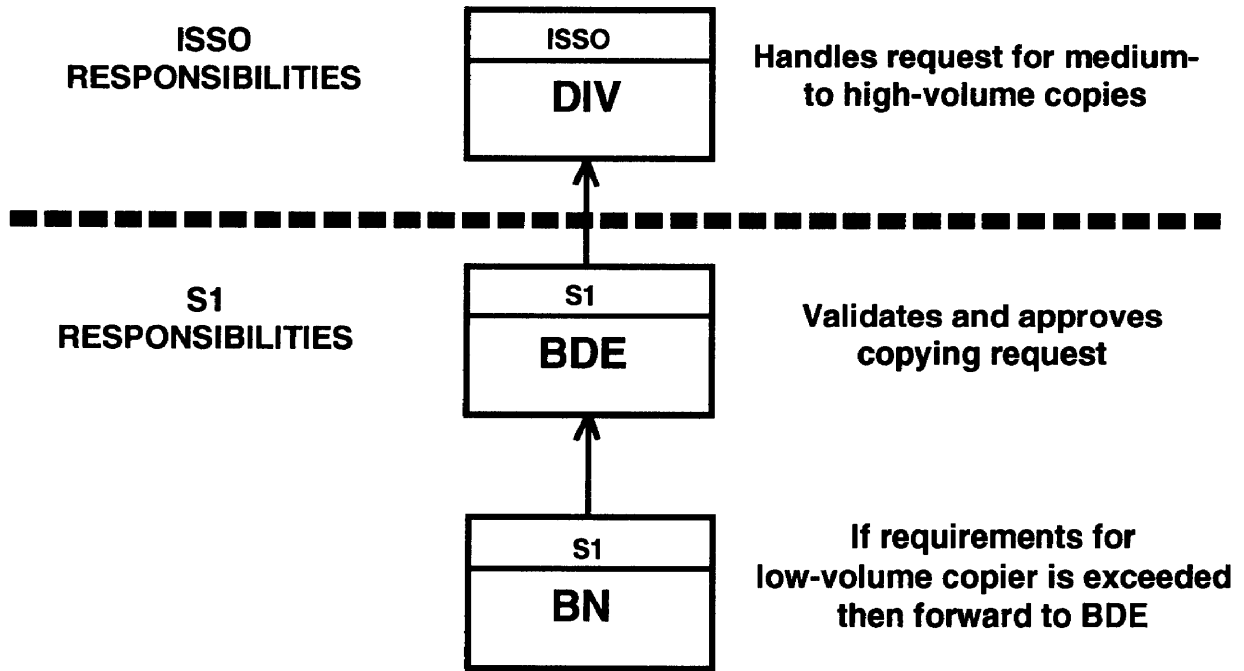

Figure 3-3. Reproduction process.

Chapter 4

Records Management

4-1. Overview

At division, corps, and theater the signal officer is responsible for staff supervision of correspondence, files, and FOIA/PA. Staff supervision includes interpreting and overseeing compliance with established policy, doctrine, and procedures. The S1/functional staff and users manage those files, correspondence, and FOIA/PA that are administrative and are necessary for their specific mission. Certain FOIA/PA requests can be approved at any level IAW AR 25-55. If a request cannot be approved at the level received, it is forwarded to the proper approving authority.

4-2. Correspondence Responsibilities

- a. **ISSO.** The ISSO--
 - Is responsible for staff supervision of correspondence IAW AR 25-50.
 - Recommends local procedures and conventions governing authentication.
 - Establishes distribution plans.
 - Recommends local procedures governing reading files.
- b. **S1.** The S1--
 - Creates, edits, and authenticates correspondence for the commander.
 - Forwards correspondence through the ISSO for distribution.
- c. **Functional Staff.** The functional staff--
 - Is responsible for the management and input of the reading file.
 - Forwards correspondence to the S1 and the ISSO for distribution.

FM 11-75

d. **User.** Users--

- Create and edit correspondence for the commander.
- Are responsible for quality control of correspondence.
- Provide input to the reading file.

e. **Correspondence.** Table 4-1 lists the correspondence responsibilities from battalion through theater.

Table 4-1. Correspondence responsibilities.

CORRESPONDENCE				
<p>SigO and ISSO refer to Signal Corps responsibilities, user refers to user responsibilities, staff refers to functional staff responsibilities, S1 refers to S1 responsibilities, and CDR refers to commander responsibilities. S1 provides all ISSO services at battalion and brigade.</p>				
RESPONSIBILITIES	BN	BDE	DIV/CORPS	THEATER
Staff supervision of correspondence recommending local procedures and conventions governing authentication (who, what, when, how)	SigO	SigO	ISSO	ISSO
Preparing correspondence	User	User	User	User
Establishing distribution schemes	S1	S1	ISSO	ISSO
Authenticating correspondence (authentication is defined as approved for release)	CDR	CDR	CDR	CDR
Reading file <ul style="list-style-type: none"> • management • input • recommending local procedures governing reading files 	Staff User S1	Staff User S1	Staff User ISSO	Staff User ISSO
<p>Once the correspondence has been authenticated, it becomes "distribution" and then a "file."</p>				

4-3. Files Management Responsibilities

a. **ISSO.** The ISSO--

- Is responsible for staff supervision of files management.
- Recommends policies, procedures, and conventions for files management IAW AR 25-400-2.
- Approves file listings and electronic conventions.
- Verifies accuracy and provides guidance on preparing records holding packages.

b. **S1.** The S1--

- Transfers eligible inactive files to the records holding area.
- Approves records transmittal listings.
- Conducts records management inspections.
- Establishes records management training.

c. **Functional Staff/User.** Staff/users maintain their own files and transfer them to the records holding area through the S1 and the ISSO.

d. **Files.** Table 4-2 lists the files management responsibilities from battalion through theater.

Table 4-2. Files management responsibilities.

FILES MANAGEMENT				
<p>SigO and ISSO refer to Signal Corps responsibilities, user refers to user responsibilities, staff refers to functional staff responsibilities, and S1 refers to S1 responsibilities. S1 provides all ISSO services at battalion and brigade.</p>				
RESPONSIBILITIES	BN	BDE	DIV/CORPS	THEATER
Staff supervision of files management recommending policies, procedures, and conventions	SigO	SigO	ISSO	ISSO
Files transfer to records holding area	S1	S1	ISSO	ISSO
Approval of file listing	S1	S1	ISSO	ISSO
Files maintenance	Staff/User	Staff/User	Staff/User	Staff/User

4-4. FOIA/PA Responsibilities

a. **ISSO.** The ISSO--

- Is responsible for supervision of FOIA/PA.
- Recommends policies, procedures, and conventions IAW AR 25-55, AR 25-1, and AR340-21.
- Enters requests into a formal control system.
- Determines and refers requests to the appropriate action office for response.
- Clears requests upon receipt of response from action office.
- Dispatches responses to requester.
- Compiles data for the annual FOIA/PA reports.
- Maintains complete case files.
- Is the POC for FOIA/PA at division, corps, and theater.

- b. **S1.** The S1--
 - Ensures each responsible individual is familiar with FOIA/PA regulations and local procedures.
 - Determines if requested information or material is releasable IAW AR 25-55.
 - Forwards requests immediately to the FOIA/PA official for entry into the formal control system.
 - Ensures the FOIA/PA request is processed and information is provided to FOIA/PA official within 10 working days.
- c. **Functional Staff/User.** Staff/users--
 - Implement FOIA/PA.
 - Process FOIA/PA requests in its areas of responsibility.
- d. **FOIA and PA.** Tables 4-3 and 4-4 list the FOIA and PA responsibilities from battalion through theater. Figure 4-1 illustrates the FOIA/PA process.

Table 4-3. FOIA responsibilities.

FREEDOM OF INFORMATION ACT (FOIA)				
<p>SigO and ISSO refer to Signal Corps responsibilities, user refers to user responsibilities, staff refers to functional staff responsibilities, and S1 refers to S1 responsibilities. S1 provides all ISSO services at battalion and brigade.</p>				
RESPONSIBILITIES	BN	BDE	DIV/CORPS	THEATER
Staff supervision of FOIA recommending policies, procedures, and conventions	SigO	SigO	ISSO	ISSO
POC for FOIA	S1	S1	ISSO	ISSO
Implementation of FOIA	User	User	User	User

Table 4-4. PA responsibilities.

PRIVACY ACT (PA)				
<p>SigO and ISSO refer to Signal Corps responsibilities, user refers to user responsibilities, staff refers to functional staff responsibilities, and S1 refers to S1 responsibilities. S1 provides all ISSO services at battalion and brigade.</p>				
RESPONSIBILITIES	BN	BDE	DIV/CORPS	THEATER
Staff supervision of Privacy Act recommending policies, procedures, and conventions	SigO	SigO	ISSO	ISSO
POC for Privacy Act	S1	S1	ISSO	ISSO
Implementation of Privacy Act	User	User	User	User

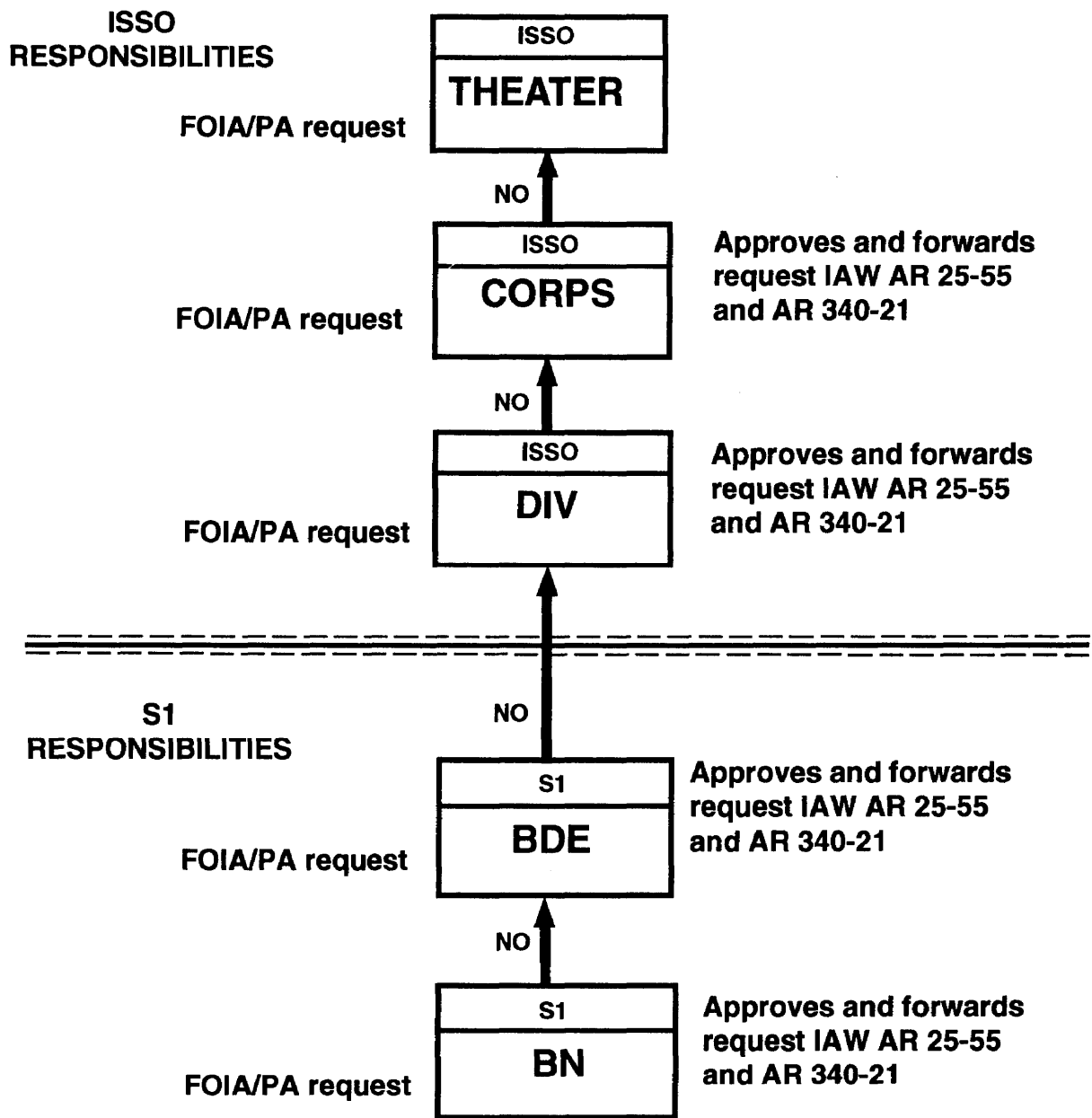

Figure 4-1. FOIA/PA process.

4-5. Classified Document Control Responsibilities

a. **ISSO.** The ISSO is responsible for temporary control and storage of classified documents awaiting distribution. It recommends classified document policies, procedures, and inspections IAW AR 380-5. The ISSO does not perform TOP SECRET document control nor does it operate a centralized TOP SECRET repository in garrison. The DOIM operates TOP SECRET repositories in garrison.

b. **S1.** The S1 performs--

- Classified document distribution and storage.
- Top Secret document destruction (at commander's discretion).

c. **Functional Staff/User.** Staff/users provide--

- Derivative classification responsibility.
- Classified document storage.
- TOP SECRET repositories.
- SECRET document destruction.
- Classified document control as correspondence or files.

d. **Classified document control.** Table 4-5 lists the classified document control responsibilities from battalion through theater. Figure 4-2 illustrates the tactical classified document control process.

Table 4-5. Classified document control responsibilities.

CLASSIFIED DOCUMENT CONTROL				
<p>SigO and ISSO refer to Signal Corps responsibilities user refers to user responsibilities, staff refers to functional staff responsibilities, S1 refers to S1 responsibilities, and CDR refers to commander responsibilities. S1 provides all ISSO services at battalion and brigade.</p>				
RESPONSIBILITIES	BN	BDE	DIV/CORPS	THEATER
Staff supervision of classified document control recommending classified document policies, procedures, and inspections (see note)	SigO	SigO	ISSO	ISSO
Classification authority	*	*	CDR	CDR
Classified document distribution	S1	S1	ISSO	ISSO
Classified document storage (see note) TOP SECRET repository (while awaiting distribution)	User	User	ISSO	ISSO
	Staff	Staff	ISSO	ISSO
Classified document control as correspondence or file	User	User	User	User
Document destruction • SECRET • TOP SECRET	User	User	User	User
	**	**	ISSO	ISSO
<p>NOTE: Classified document control must apply in phases and areas of the IMA (for example, correspondence, printing/reproduction, distribution/mail, and file management). Because signal is so involved in classified document control and because of this area's criticality, another proponent—the intelligence community—must set and enforce the standards. The ISSO will only be responsible for temporary storage of classified documents awaiting distribution.</p>				
<p>* No user original classification authority authorized at this level. (See AR 380-5.)</p>				
<p>** Can be either S1 or S2 depending on the commander's discretion.</p>				

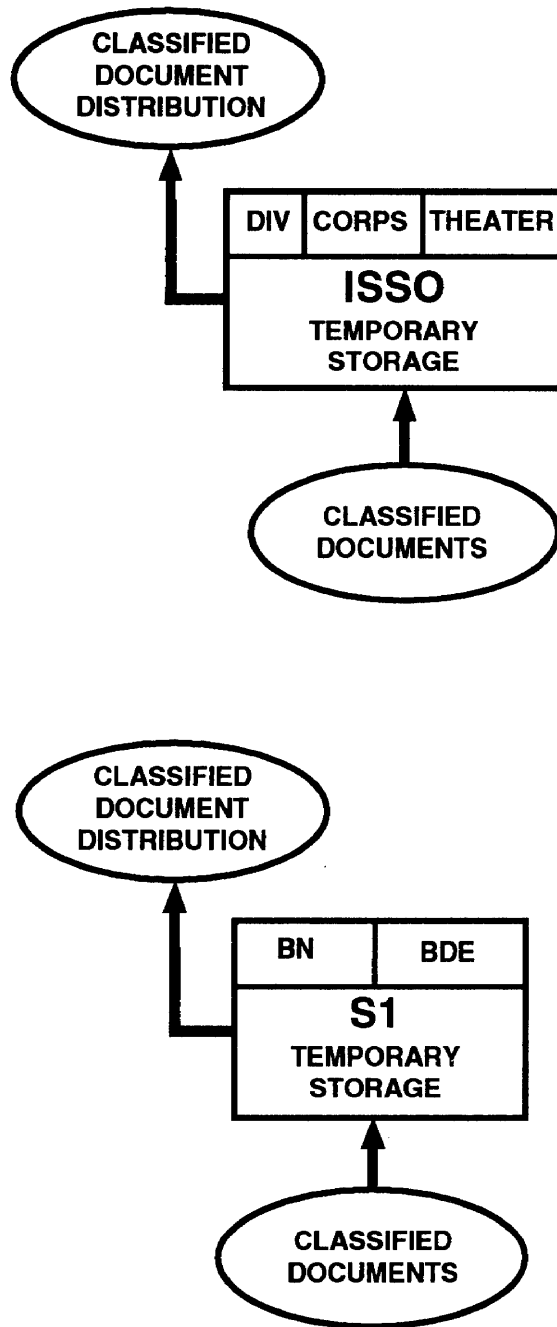

Figure 4-2. Tactical classified document control process.

4-6. Distribution/Official Mail Responsibilities

a. **ISSO/S1 (Distribution).** The ISSO/S1---

- Is responsible for staff supervision of distribution.
- Recommends policies, procedures, and conventions.
- Maintains accountable distribution including official mail. (The S1 also maintains accountable distribution.)
- Is responsible for internal headquarters distribution. (This includes distribution center operations and distribution pickup.)
- Coordinates with G3 for unit taskings to augment necessary messenger services.

b. **ISSO/S1 (Official Mail).** The ISSO/S1--

- Follows postal regulations in processing official mail.
- Picks up and distributes official mail from higher headquarters. (Once mail is delivered, it becomes normal distribution within the unit.)
- Coordinates pick up of official mail by lower echelon units.
- Determines if mail is mailable IAW US postal service regulations.
- Checks that all addresses and return addresses have a ZIP+4 code/APO and an assigned unit/consolidated mailroom (CMR) or unit number.
- Inspects mail for proper packaging, wrapping, and conformity to size and weight limitations.
- Checks parcels for appropriate customs declaration forms.
- Checks that unaccompanied baggage mailed from APOs to CONUS by a transportation officer is correctly prepared and screened before loading onto any aircraft. Follow Military Airlift Command (MAC) mail security screening requirements.

c. **Functional Staff/Users.** Staff/users are responsible for picking up distribution and censoring mail.

d. **Distribution/official mail.** Table 4-6 lists the distribution/official mail responsibilities from battalion through theater. Figure 4-3 illustrates the distribution/official mail process.

Table 4-6. Distribution/official mail responsibilities.

DISTRIBUTION/OFFICIAL MAIL				
<p>SigO and ISSO refer to Signal Corps responsibilities, user refers to user responsibilities, staff refers to functional staff responsibilities, and S1 refers to S1 responsibilities. S1 provides all ISSO services at battalion and brigade.</p>				
RESPONSIBILITIES	BN	BDE	DIV/CORPS	THEATER
Staff supervision of distribution recommending policies, procedures, and conventions	SigO	SigO	ISSO	ISSO
Internal HQ distribution <ul style="list-style-type: none"> • distribution center operations • pickup of distribution 	S1 User	S1 User	ISSO User	ISSO User
External distribution service <ul style="list-style-type: none"> • recommending policies, procedures, and conventions • providing resources for necessary messenger service. (Maximum use is made of existing delivery systems.) • coordinating resources for messenger service 	S1 User	S1 User	ISSO User	ISSO User
Official mail <ul style="list-style-type: none"> • official mail, internal distribution • censorship 	S1 User	S1 User	ISSO User	ISSO User
<p>NOTE: Mail may be categorized as official or personal; however, once official mail is received by a unit, it becomes normal distribution. Personal mail remains mail, subject to postal regulation, until delivered to the intended recipient. Official mail contains military information. Personal mail contains personal information sometimes subject to censorship. Personal mail is an Adjutant General's Corps and Army Postal Office responsibility.</p>				

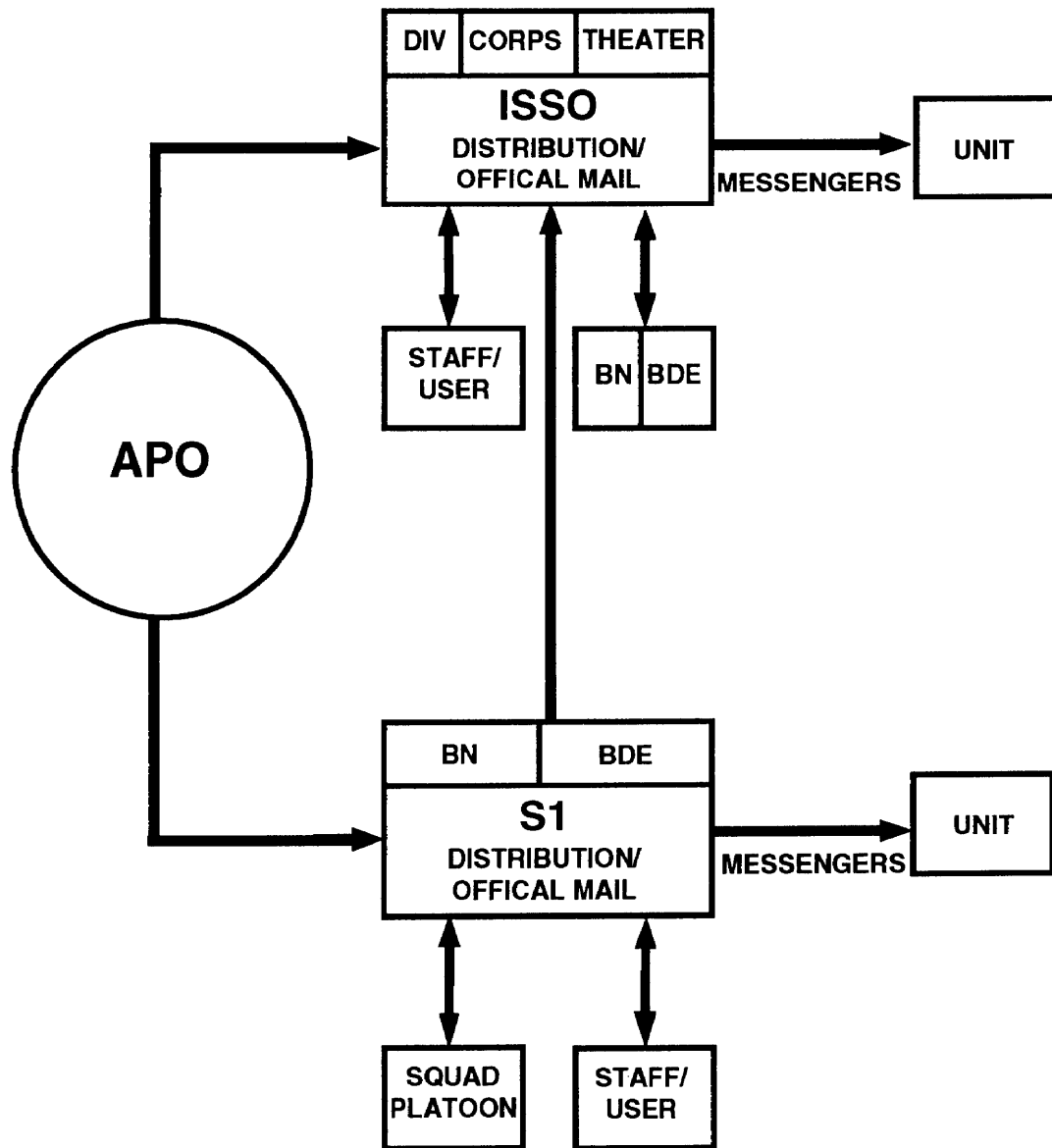

Figure 4-3. Distribution/official mail process.

Glossary

Acronyms and Abbreviations

ACSO	assistant corps signal officer
ADSO	assistant division signal officer
APO	Army Post Office
AR	Army regulation
attn	attention
BAS	battlefield automated systems
BAN	battlefield account number
bde	brigade
BIS	Battlefield Information Services
bn	battalion
CDR	commander
CMR	consolidated mailroom
CofS	Chief of Staff
CONUS	continental United States
CP	command post
CPM	copies per minute
CTA	common table of allowances
DA Pam	Department of the Army Pamphlet
DA	Department of the Army
DCSIM	Deputy Chief of Staff for Information Management
div	division
DOD/DD	Department of Defense/used with forms
DOIM	Director of Information Management
FM	field manual
FOIA	Freedom of Information Act
G2	Assistant Chief of Staff, G2 (Intelligence)
G3	Assistant Chief of Staff, G3 (Operations and Plans)
GPS	General Printing Service
HQ	headquarters
IAW	in accordance with
IMA	Information Mission Area
ISSB	Information Services Support Branch
ISSO	Information Services Support Office
MAC	Military Airlift Command
MTOE	modification table of organization and equipment
PA	Privacy Act
POC	point of contact
S1	Adjutant (US Army)
S2	Intelligence Officer (US Army)
S3	Operations and Training Officer (US Army)

FM 11-75

S4	Supply Officer (US Army)
SigO	signal officer
SOP	standing operating procedure
TDC	tactical document copier
TDD	tactical deployable duplicator
TOE	table(s) of organization and equipment
TRADOC	United States Army Training and Doctrine Command
TSC(A)	Theater Signal Command (Army)
US	United States (of America)
USAPPC	United States Army Printing and Publications Command

References

Sources Used

These are the sources quoted or paraphrased in this publication.

Department of the Army (DA) Form

DA Form 2028. *Recommended Changes to Publications and Blank Forms*. February 1974.

Department of Defense (DD) Form

DD Form 843. *Requisition for Printing and Binding Service*. July 1955.

Field Manual (FM)

FM 24-1. *Signal Support in the AirLand Battle*. 15 October 1990.

FM 24-1. *Signal Support and the Information Mission Area*. **Coordinating Draft dated May 1993. Will supersede FM 24-1 dated 15 October 1990 when published.**

Documents Needed

These documents must be available to the intended users of this publication.

Army Regulations (AR)

*AR 25-1. *The Army Information Resources Management Program*. 18 November 1988.

*AR 25-30. *The Army Integrated Publishing and Printing Program*. 28 February 1989.

***This source was used to develop this publication.**

FM 11-75

Army Regulations (AR) (continued)

- *AR 25-50. *Preparing and Managing Correspondence*. 21 November 1988.
- *AR 25-51. *Official Mail and Distribution Management*. 30 November 1992.
- *AR 25-55. *The Department of the Army Freedom of Information Act Program*. 10 January 1990.
- *AR 25-400-2. *The Modern Army Recordkeeping System (MARKS)*. 26 February 1993.
- *AR 71-13. *The Department of the Army Equipment Authorization and Usage Program*. 03 June 1988.
- *AR 340-21. *The Army Privacy Program*. 5 July 1985
- *AR 380-5. *Department of the Army Information Security Program*. 25 February 1988.

Common Table of Allowances (CTA)

- *CTA 50-909. *Field and Garrison Furnishings and Equipment*. 01 June 1989.

Department of the Army (DA) Pamphlet

- *DA Pam 25-33. *The Standard Army Publication System (STARPUBS): Revision of the DA-Series Forms, Usages and Procedures*. 01 June 1988.

Readings Recommended

This reading contains relevant supplemental information.

Field Manuals (FM)

- FM 11-41. *Signal Support: Echelons Corps and Below (ECB)*. 18 December 1991.

***This source was used to develop this publication.**

References-2

Field Manuals (FM) (continued)

FM 11-45. *Signal Support: Echelons Above Corps (EAC)*. **Final Draft dated September 1993. Will superseded FM 11-23 dated November 1978 when published.**

FM 11-50. *Combat Communications Within the Division (Heavy and Light)*. 04 April 1991.

FM 12-6. *Personnel Doctrine*. 23 August 1989.

Index

- automation, iii
- BAN. *See* battlefield account number.
- BAS. *See* battlefield automated systems.
- battlefield, iii, 1-1--1-5, 2-2, 2-4, 3-2, 3-4, 3-8
 - account number, 3-4, 3-8
 - automated systems, 3-2
 - information services, iii, 1-1--1-3
 - classified document control, iii, 1-2, 2-4, 2-5, 4-8--4-10
 - correspondence, iii, 1-2, 2-2, 4-1, 4-2
 - distribution/official mail, iii, 1-2, 1-4, 2-2, 2-4, 2-5, 4-11--4-13
 - files management, iii, 1-2, 2-4, 4-3, 4-4
 - forms management, iii, 1-1, 3-8, 3-9
 - freedom of information act, iii, 1-2, 1-4, 2-1, 2-3, 3-8, 4-4--4-7
 - management, 1-4, 2-2
 - organization, 1-4, 1-5
 - printing, iii, 1-1, 3-1--3-3
 - privacy act, iii, 1-1, 1-2, 1-4, 2-1, 2-3, 4-4--4-7
 - publications, iii, 1-1, 2-2, 2-3, 3-2, 3-4--3-7
 - reproduction, iii, 1-2, 3-9--3-12
 - responsibilities, 1-2--1-4
- BIS. *See* battlefield information services.
- classified document control, iii, 1-2, 2-4, 2-5, 4-8--4-10
 - policies, 2-5
 - process, 4-8, 4-10
 - responsibilities, 4-8, 4-9
 - battalion through theater, 4-8, 4-9
 - CDR, 4-9
 - functional staff, 4-8, 4-9
 - ISSO, 4-8, 4-9
 - S1, 4-8, 4-9
 - SigO, 4-9
 - User, 4-8, 4-9
- communications, iii
- correspondence, iii, 1-2, 2-2, 4-1, 4-2
 - repository, 2-2
 - responsibilities, 4-1, 4-2
 - battalion through theater, 4-2
 - CDR, 4-2
 - functional staff, 4-1
 - ISSO, 4-1

FM 11-75

- S1, 4-1
- SigO, 4-2
- user, 4-2

- direct action, 1-4
 - distribution, 1-4
 - FOIA/PA, 1-4
 - reproduction requirements, 1-4
- Director of Information Management, 1-1, 2-3
- distribution, iii, 1-4, 2-4, 2-5, 4-11--4-13
 - external, 1-4, 2-5, 4-12
 - internal, 1-4, 4-12
 - process, 4-11, 4-13
 - responsibilities, 4-11, 4-12
 - battalion through theater, 4-11, 4-12
 - functional staff, 4-11
 - ISSO, 4-11, 4-12
 - S1, 4-11, 4-12
 - SigO, 4-12
 - user, 4-11, 4-12

DOIM. *See* Director of Information Management.

- Files, iii, 1-2, 2-4, 4-3, 4-4
 - management, iii, 1-2, 2-4, 4-3, 4-4
 - records management, 1-2
 - responsibilities, 4-3, 4-4
 - battalion through theater, 4-3, 4-4
 - functional staff, 4-3, 4-4
 - ISSO, 4-3, 4-4
 - S1, 4-3, 4-4
 - SigO, 4-4
 - user, 4-3, 4-4

FOIA. *See* Freedom of Information Act.

- Forms, iii, 1-1, 3-8, 3-9
 - management, iii, 1-1, 3-8, 3-9
 - responsibilities, 3-8, 3-9
 - battalion through theater, 3-8, 3-9
 - functional staff, 3-8, 3-9
 - ISSO, 3-8, 3-9
 - S1, 3-8, 3-9
 - SigO, 3-9
 - user, 3-8, 3-9

Freedom of Information Act, iii, 1-2, 1-3, 2-1, 2-3, 3-8, 4-4--4-7
 process, 4-1, 4-4, 4-5, 4-7
 responsibilities, iii, 1-2, 1-3, 2-1, 2-3, 4-5
 battalion through theater, 4-5
 functional staff, 4-5
 ISSO, 4-4
 S1, 4-5
 SigO, 4-5
 user, 4-5

General Printing Service, 3-10

headquarters and operations section, 2-2

IMA. *See* Information Mission Area.

Information Mission Area, iii, 1-1

 disciplines, iii, 1-1, 1-2, 1-4, 2-2--2-4, 3-1--3-12, 4-1--4-13
 automation, iii
 communications, iii
 printing, iii, 1-1, 3-1--3-3
 publications, iii, 1-1, 2-2, 2-3, 3-2, 3-4--3-7
 records management, iii, 1-1, 1-2, 1-4, 2-2, 2-4, 3-9--3-12, 4-1--4-13
 visual information, iii

Information Services Support Branch, 1-3

Information Services Support Office, iii, 1-2--1-4, 2-1--2-5, 3-1, 3-2, 3-4, 3-8, 3-9, 4-1, 4-3, 4-4, 4-6, 4-8, 4-9, 4-11, 4-12

 distribution center, 2-2
 functions, 1-3, 2-1, 2-2, 2-5, 3-8
 mission, 2-1
 organization, 2-1--2-5
 headquarters and operations section, 2-2, 2-3,
 publications and reproduction section, 2-2, 2-3, 2-4
 records management and distribution section, 2-2, 2-4, 2-5
 responsibilities, 2-2--2-4, 3-1
 section personnel, 2-2--2-4
 standing operating procedure, 2-3

ISSB. *See* Information Services Support Branch.

ISSO. *See* Information Services Support Office.

MAC. *See* military airlift command.

management policy, 1-4

Military Airlift Command, 4-11

messenger service, 2-5

FM 11-75

- official mail, iii, 1-2, 1-4, 2-2, 2-4, 4-11--4-13
 - pick-up, 2-2, 2-4
 - process, 4-11, 4-13
 - responsibilities, 4-11--4-13
 - battalion through theater, 4-11, 4-12
 - functional staff, 4-11
 - ISSO, 4-11
 - S1, 4-11
 - user, 4-11

- PA. *See* privacy act.
- printing, iii, 1-1, 3-1--3-3
 - process, 3-2, 3-3
 - responsibilities, 3-1, 3-2
 - battalion through theater, 3-2
 - corps and below, 3-1
 - functional staff, 3-1, 3-2
 - ISSO, 3-1, 3-2
 - S1, 3-2
 - theater reproduction detachments, 3-1--3-3
 - user, 3-1, 3-2
 - tactical deployable duplicators, 3-1, 3-10, 3-11
 - tactical document copiers, 3-1
 - subscriber terminals, 3-1
- privacy act, iii, 1-2, 1-3, 2-1, 2-3, 4-4--4-7
 - process, 4-4, 4-5, 4-7
 - responsibilities, 4-5, 4-6
 - battalion through theater, 4-5
 - functional staff, 4-5
 - ISSO, 4-4, 4-6
 - S1, 4-5, 4-6
 - SigO, 4-6
 - user, 4-5
- publications, iii, 1-1, 2-2, 2-3, 3-2, 3-4--3-7
 - forms distribution, 3-5--3-7
 - reproduction section, 2-2, 2-3
 - responsibilities, 3-2, 3-4, 3-6
 - functional staff, 3-5
 - ISSO, 3-4
 - S1, 3-5, 3-6
 - SigO, 3-6
 - user, 3-5

records management, iii, 1-1, 1-2, 1-4, 2-2, 2-4, 3-9--3-12, 4-1--4-13
 management and distribution section, 2-2, 2-4
 program, 2-4
 reproduction, iii, 1-2, 3-9--3-12
 process, 3-12
 requirements, 1-4
 responsibilities, 3-9, 3-11
 battalion through theater, 3-11
 functional staff, 3-10, 3-11
 general printing service, 3-10
 ISSO, 3-9
 S1, 3-10, 3-11
 TSC(A), 3-10
 user, 3-10, 3-11
 self-service copiers, 3-10
 TDD, 3-1, 3-10, 3-11

 subscriber terminals, 3-1

 tactical, 3-1, 3-10, 3-11, 4-8, 4-10
 classified document control process, 4-8, 4-10
 deployable duplicators, 3-1, 3-10, 3-11
 document copiers, 3-1
 TDC. *See* tactical document copiers.
 TDD. *See* tactical deployable duplicators.
 Theater Signal Command (Army), 3-1, 3-10

 United States Army Printing and Publications Command (USAPPC), 3-4, 3-8

 visual information, iii

FM 11-75
20 SEPTEMBER 1994

By Order of the Secretary of the Army:

Official:

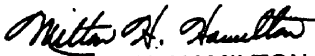
MILTON H. HAMILTON
*Administrative Assistant to the
Secretary of the Army*

07148

GORDON R. SULLIVAN
*General, United States Army
Chief of Staff*

DISTRIBUTION:

Active Army, USAR, ARNG: To be distributed in accordance with DA Form 12-11E, requirements for FM 11-75, Battlefield Information Services (BIS) (Qty rqr block no. 5172)